

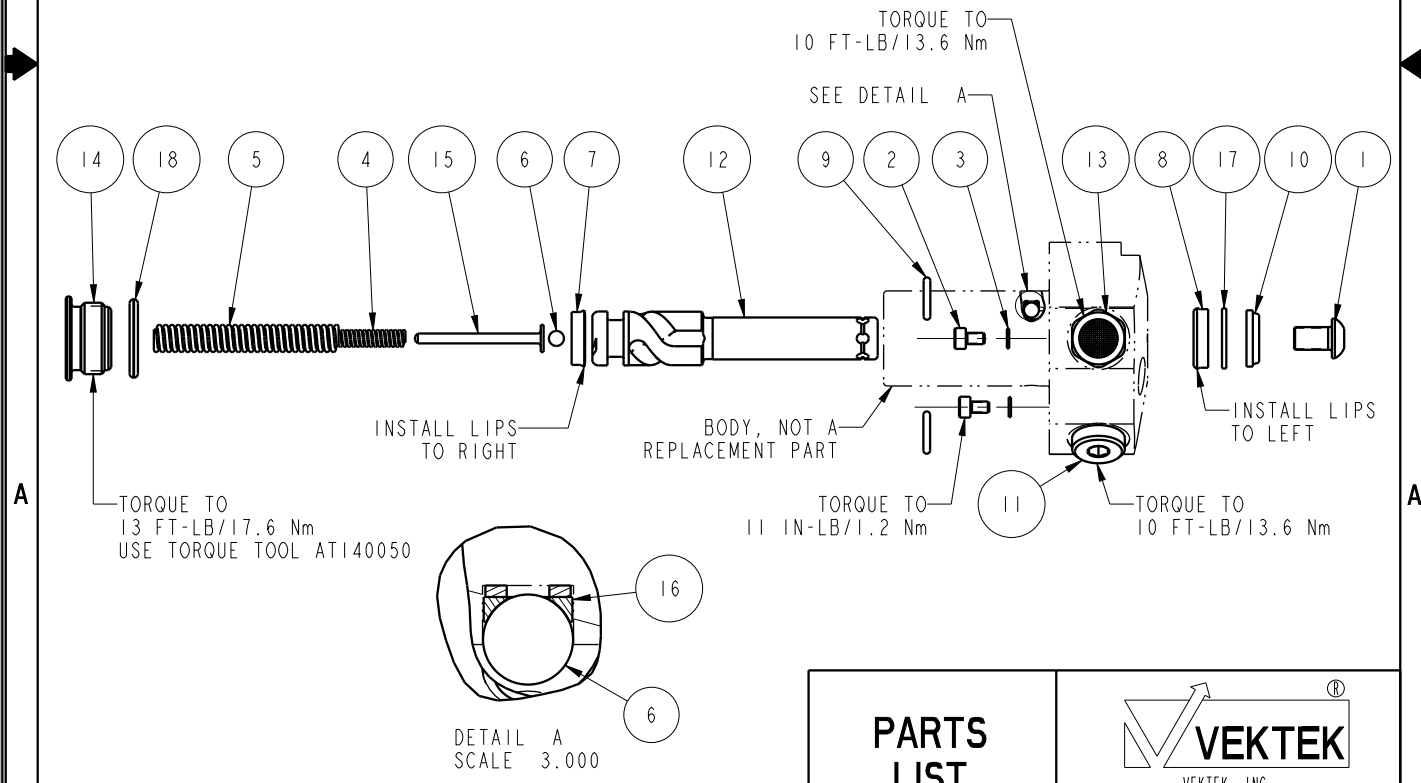

NO	QTY	PART NO	DESCRIPTION	STD SEAL KIT	FKM SEAL KIT	SPRING KIT
1	1	21500008	SCREW, CAP, BTNH, M6 X 10, ALY			
2	2	21500018	SCREW, CAP, SOCH, M3 X 5, ALY			
3	2	21500200	WASHER			
4	1	23310008	SPRING, COMPRESSION			X
5	1	23311017	SPRING, COMPRESSION			X
6	4	23600014	BALL, STEEL, ALLOY, .156	X	X	X
7	1	39010036	SEAL, BEVEL, 3/8 x 3/32 x 9/16	X	39052010	
8	1	39010038	SEAL, BEVEL, 7/16 x 3/32 x 5/8	X	39052014	
9	2	39050042	O-RING, (-011)	X	39051025	X
10	1	39053004	WIPER, SNAP-IN, (7/16)	X	X	
11	1	43068004	PLUG, SOCH, G1/8			
12	1	47510504	PLUNGER, SC, HS, 2KN, RH			
13	1	49001904	BREATHER, 1/8 BSPP			
14	1	81400028	RETAINER, SC, HS, 450			
15	1	81590501	ROD, SUPPORT, SPRING, SC, 450			X
16	3	90199956	ASSY, BALLSEAT, SC, 450	X	X	
17	1	39F54000	BU RING, (-111)	X	X	
18	1	39V00036	O-RING, (-908)	X	X	X
N/A	N/A	60414301	KIT, SEAL, STANDARD			
N/A	N/A	6V414301	KIT, SEAL, FKM			
N/A	N/A	61414001	KIT, SPRING			



PARTS LIST	 VEKTEK VEKTEK, INC. 1334 E. SIXTH AVE. P.O. BOX 625 EMPORIA, KS. 66801 U.S.A.	
	PARTS LIST, ASSY, SC, TF, TC, 2KN, SA, RH	
ASSEMBLIES AFFECTED 41460211	SIZE A	REV C

C	5279	RELEASE	ALS	4/25/24
REV	IN ACCORDANCE WITH ECN	EFFECTIVE DATE	REVISED BY	DATE
DRW BY:	JDW	DRAWING STATUS: Released PRODUCTION APPROVED FOR RELEASED STATUS ONLY		
DATE:	03/13/13			